



Aluminium windows & doors

THE ULTIMATE EUROPEAN QUALITY

SLIDING SYSTEMS

SCHÜCO



SLIDE INTO OUR WORLD OF ELEGANCE

ROPEAN QUALITY
OR PERFECTION
MINIUM SYSTEMS
ROPEAN QUALITY
OR PERFECTION
MINIUM SYSTEMS
ROPEAN QUALITY
OR PERFECTION

INNOVATIVE - CERTIFIED EUROPEAN ALUMINIUM SYSTEMS
PREMIUM QUALITY - LUXURY - ULTIMATE EUROPEAN QUALITY
THE HOME OF EXCELLENCE - STRIVE FOR PERFECTION
INNOVATIVE - CERTIFIED EUROPEAN ALUMINIUM SYSTEMS
PREMIUM QUALITY - LUXURY - ULTIMATE EUROPEAN QUALITY
THE HOME OF EXCELLENCE - STRIVE FOR PERFECTION
INNOVATIVE - CERTIFIED EUROPEAN ALUMINIUM SYSTEMS
PREMIUM QUALITY - LUXURY - ULTIMATE EUROPEAN QUALITY
THE HOME OF EXCELLENCE - STRIVE FOR PERFECTION
INNOVATIVE - CERTIFIED EUROPEAN ALUMINIUM SYSTEMS
PREMIUM QUALITY - LUXURY - ULTIMATE EUROPEAN QUALITY
THE HOME OF EXCELLENCE - STRIVE FOR PERFECTION
INNOVATIVE - CERTIFIED EUROPEAN ALUMINIUM SYSTEMS
PREMIUM QUALITY - LUXURY - ULTIMATE EUROPEAN QUALITY
THE HOME OF EXCELLENCE - STRIVE FOR PERFECTION
INNOVATIVE - CERTIFIED EUROPEAN ALUMINIUM SYSTEMS
PREMIUM QUALITY - LUXURY - ULTIMATE EUROPEAN QUALITY
THE HOME OF EXCELLENCE - STRIVE FOR PERFECTION
INNOVATIVE - CERTIFIED EUROPEAN ALUMINIUM SYSTEMS
PREMIUM QUALITY - LUXURY - ULTIMATE EUROPEAN QUALITY
THE HOME OF EXCELLENCE - STRIVE FOR PERFECTION



Aluminium windows & doors



WE ARE THE BENCHMARK



Experience extraordinary performance with our non-insulated sliding systems, creating expansive areas within your home.

The design possibilities are limitless, ranging from corner interlocking sliding doors to cavity sliding doors. Explore our AS 39 NI TropTec sliding system featuring snap-on track profiles for seamless connection of tracks, accommodating any desired number of sliding panels. Additionally, our ASS 50 NI series, with the Lift and Slide option, can support a maximum weight of 400kg per panel. We take pride in offering meticulously engineered systems that enhance the sophistication of your home. Our diverse range of systems is tailored to meet all your bespoke requirements.



ASS 50 NI

TECHNICAL CHARACTERISTICS

- Casement of system
- Basic width of frame and sash
- Glass thickness
- Maximum weight of sash
- Maximum weight with Lift and Slide
- Interlocker thickness

50mm
121mm
6mm - 32mm
300kg
400kg
106mm

DEPTH OF ASS 50 NI SLIDING TRACKS

S: 51mm D: 120mm T: 185mm

SLIDING TRACK DIMENSIONS
ASS 50 NI - DOUBLE TRACK

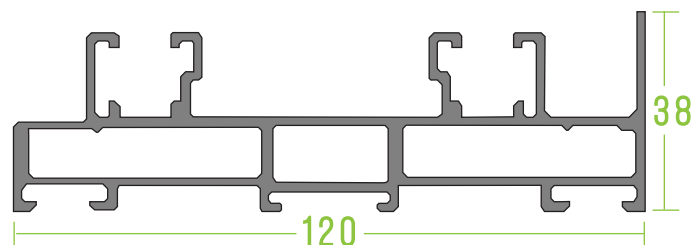

AS 39 NI TROPTEC

TECHNICAL CHARACTERISTICS

- Casement of system
- Basic width of frame and sash
- Glass thickness
- Maximum weight of sash
- Maximum weight with Lift and Slide
- Interlocker thickness

39mm
113mm
6mm - 28mm
200kg
250kg
37mm

DEPTH OF AS 39 NI TROPTEC SLIDING TRACKS

D: 107mm T: 160mm

SLIDING TRACK DIMENSIONS
AS 39 NI TROPTEC - DOUBLE TRACK

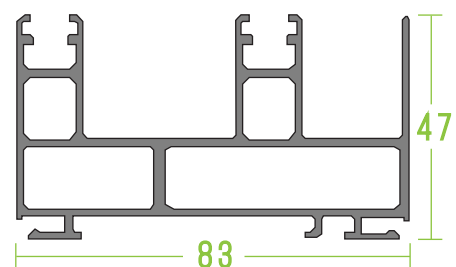



CERTIFICATES FOR AS 39 NI TROPTEC

Air permeability DIN EN 12207 Class 4

Windload resistance DIN EN 12210 Up to 3000 Pa

Watertightness DIN EN 1027/12208 Class 9A

Sound insulation EN ISO 717-1 Up to 33dB

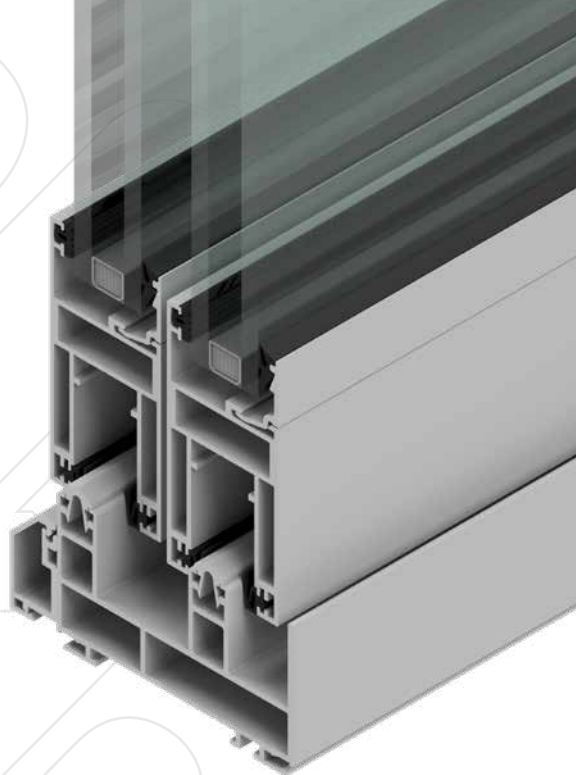

CERTIFICATES FOR ASS 50 NI

Air permeability DIN EN 12207 Class 2

Burglar resistance DIN EN 1627 RC2

TYPOLOGIES GUIDE

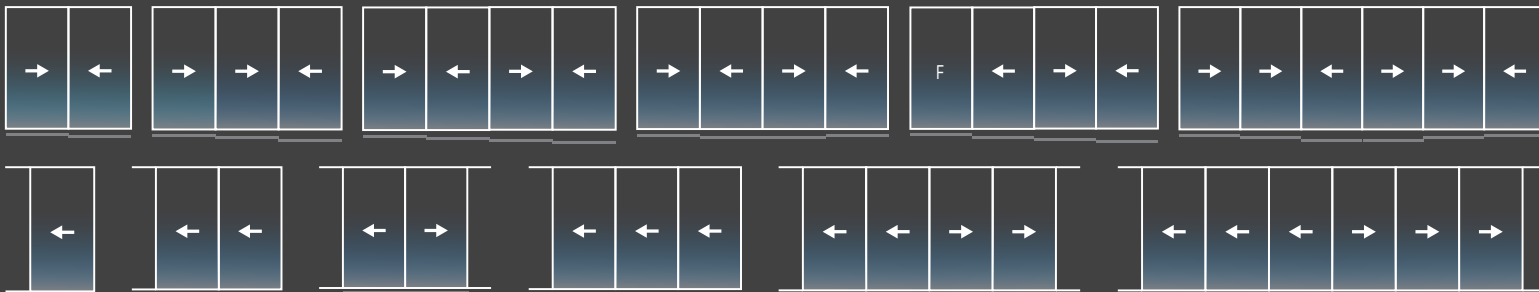

OUR VISION IS TO



- Be the benchmark against which innovation, quality and style the industry is measured
- Be the best by far at what we do
- Produce the highest quality from start to finish

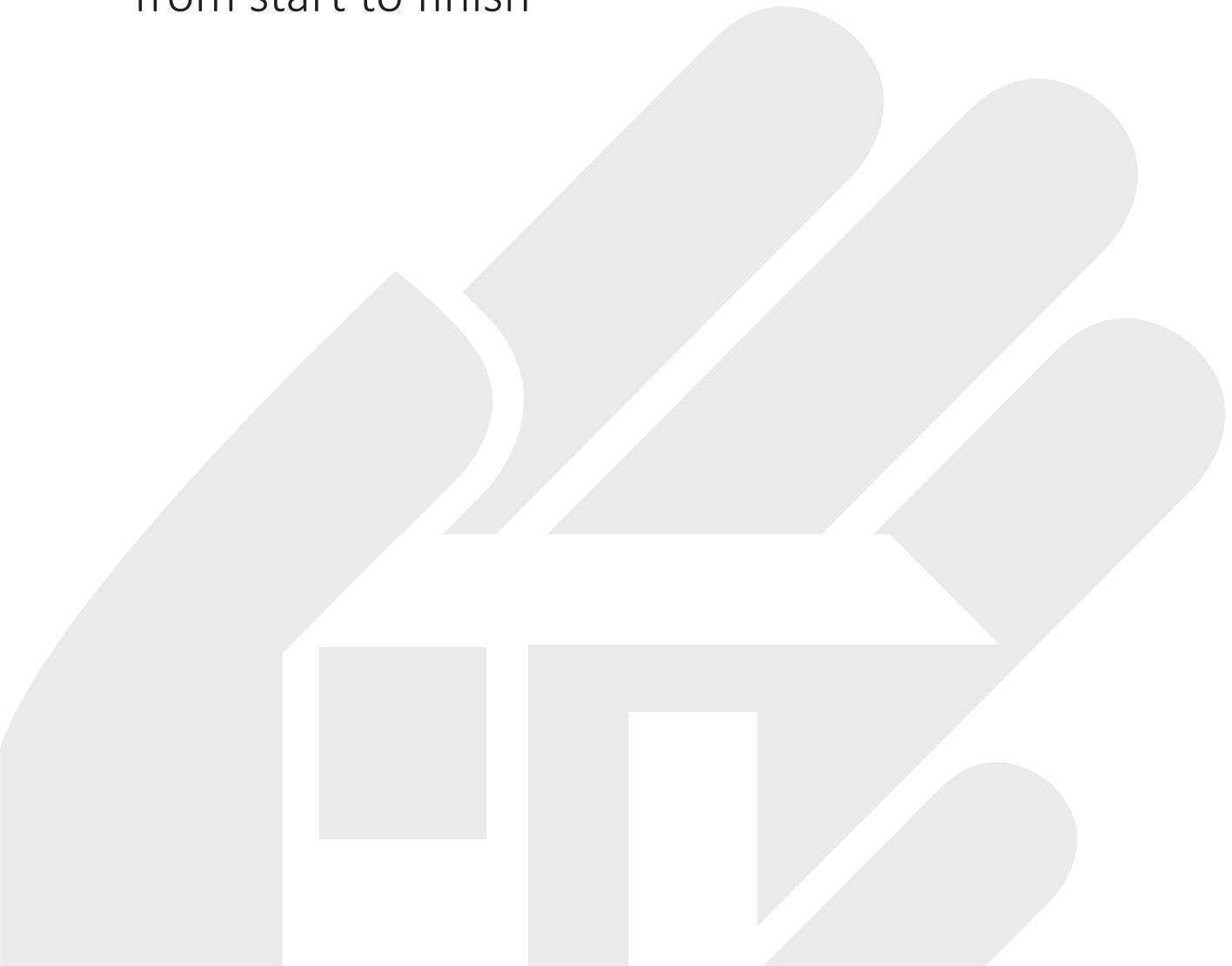

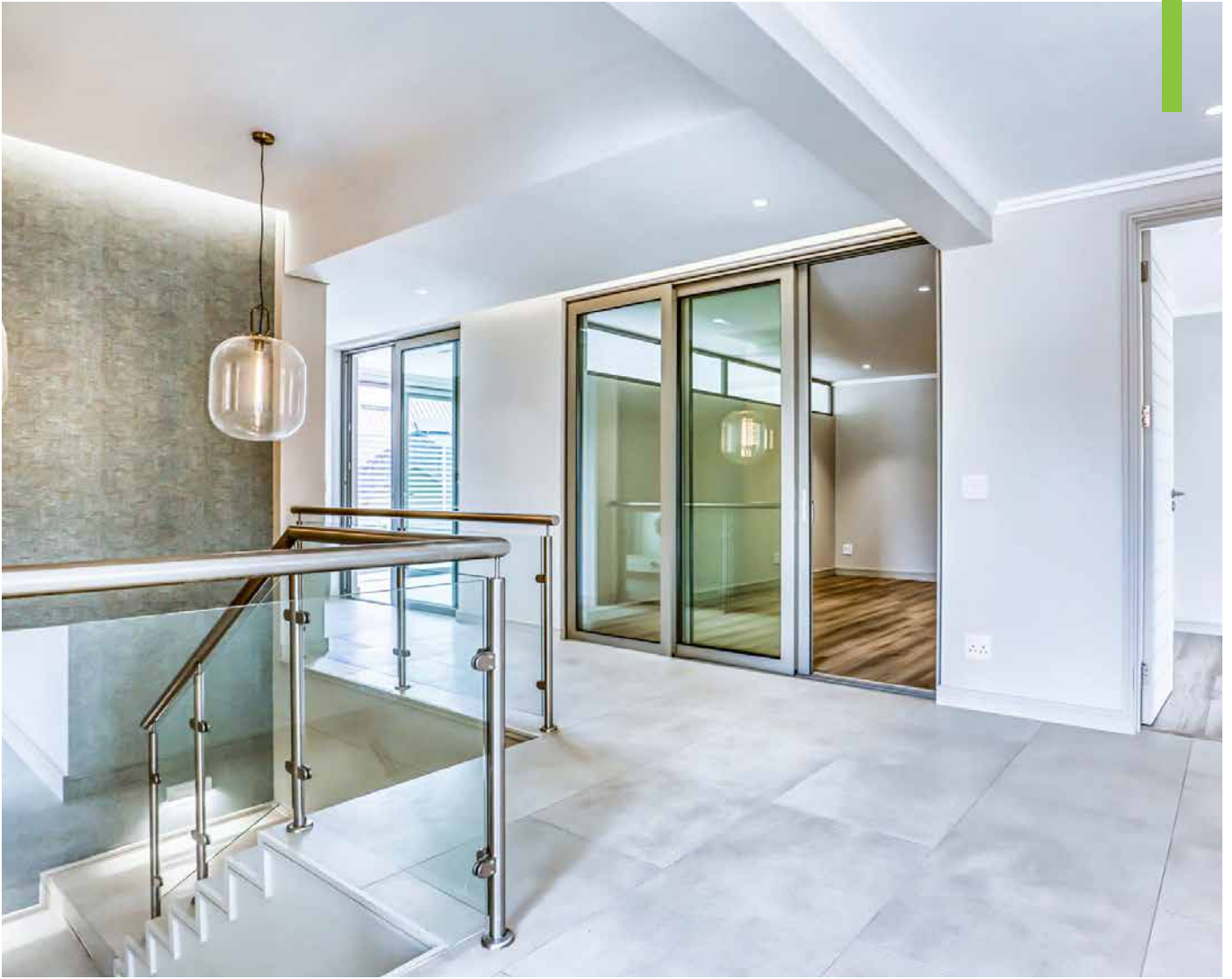

VISIT OUR SHOWROOMS

JOHANNESBURG

37 Old Kilcullen Road, Bryanston
Johannesburg
T: 011 796 5165
www.fenster.co.za
info@fenster.co.za

GEORGE

52 York Street, George
Western Cape
T: 044 220 4444
www.fenster.co.za
info@fenster.co.za

CAPE TOWN

62 Marine Drive, (Service Road), Paarden Eiland
Cape Town
T: 021 510 0921
www.fenster.co.za
info@fenster.co.za